



**OGW technology is driven by
Customer satisfaction and
R&D since 1999**

Commercial sheet
Machines and devices

OGW – 1/4VIN
820 CHEMIN DE LA TOUR
83 210 SOLLIES-PONT
FRANCE
Tél. : +33.494.13.00.15
www.oneglasswine.com

Revision march 2020

OGW – H8 line



An innovative, efficient and secure process to fill and package wine in Ready to Drink glasses.

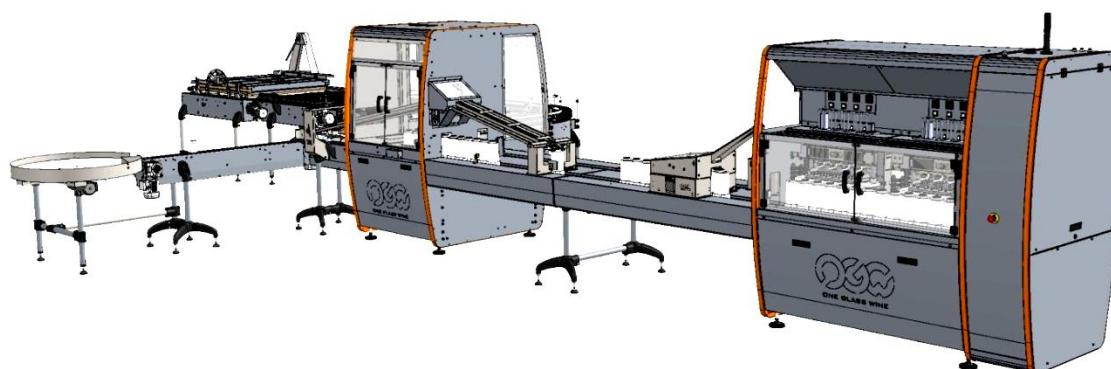

All pictures and drawings are not contractual

WE MEET YOUR REQUIREMENTS

Safety

No additive

No oxidation

Perfect inerting of the head space of glasses (shelf life up to 10 months)

Packaging sealed under vacuum

Flexibility

Compact and ergonomic design

Small footprint

Speed production up to 3,600 glasses /h

Fast format change for the various OGW glasses models.

Efficiency

Completely automated system controlled from operator panel

Great dosing precision and minimal production waste

Highly reliable system

Low maintenance

▪ H8 – FILLING AND PACKAGING MACHINE

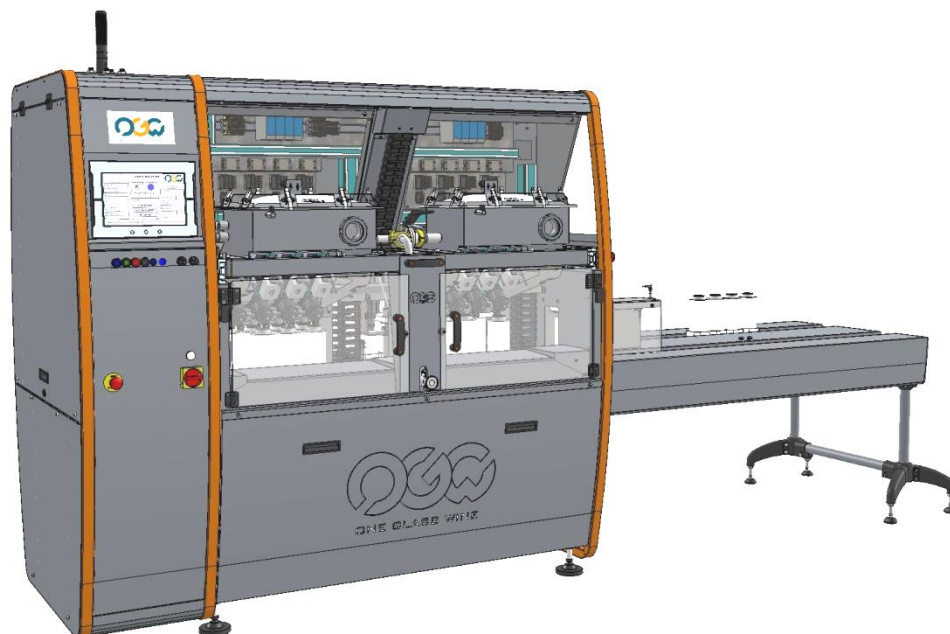

TECHNICAL DATA

Dimensions : H 2150 mm X L 3515 mm X I 1200 mm

Weight : 756 kg

Power : Electrical 230 V AC – 32A

Air Pressure : 8 bars

Filling system : volumetric filling

Approval : CE



This new generation integrates the latest innovations developed by our engineers.

H8 machine is available in 3 versions:

8 heads

4 heads

4 heads upgradable to 8 heads.

The frame and the majority of the components are **stainless steel** to offer easy cleaning.

The patented integration of buffer tanks under controlled atmosphere guarantees a **high precision of filled volumes** and a **perfect control of Dissolved O2**.

With a **reduced footprint** equivalent to the preceding U4 machines, the H8 line is working simultaneously on 8 heads for conditioning **up to 60 glasses per minute**.

All the system is controlled by an **ergonomic operator interface** displayed on a 12 inch color screen.

OGW – 1/4VIN

Tel. : +33.494.13.00.15

www.oneglasswine.com

OGW is now offering a complete range of automatic devices specially designed for the H8 machine and additional services.

▪ PICK&PLACE DEVICE



TECHNICAL DATA

Dimensions: H 1910 mm X L 1690 mm X 1480 mm

Weight: 330 kg

Approval: CE

The **P&P device** places 8 empty glasses into a correct position. An automatic arm equipped with pneumatic clamp transfers glasses from the loading table into the carrier of the filling machine.

The **Unloader device** picks each sealed glass from carriers onto the outfeed conveyor.

▪ UNLOADER DEVICE



TECHNICAL DATA

Dimensions: H 850 mm X L 2770 mm X

I 1200 mm

Weight: 40kg

Approval: CE



▪ ADDITIONAL H8 CONVEYOR

TECHNICAL DATA

Dimensions: H 840 mm X L 1150 mm X I 900 mm
 Weight: 60 kg
 Approval: CE



▪ INPUT ACCUMULATION TABLE

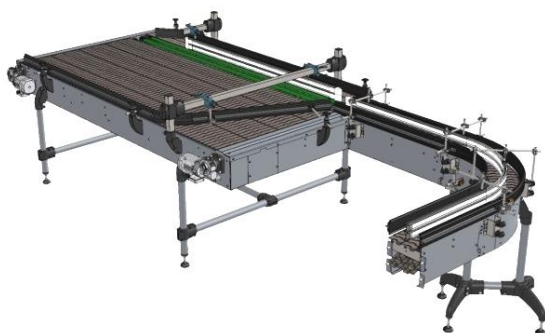

TECHNICAL DATA

Dimensions : H 1390 mm X L 4190 mm X I 1655 mm
 Weight: 310 kg
 Power: Electrical 230 V AC – 16A
 Approval: CE

With a capacity of 600 glasses (approx. 2 layers of glasses) the **Input accumulation table** has been designed to avoid the permanent presence of an operator at this stage of the filling process.



▪ GLASS SELECTOR

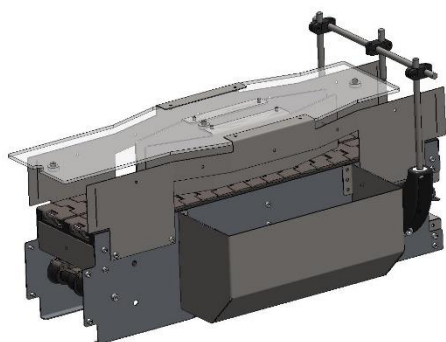

TECHNICAL DATA

Dimensions : H 435 mm X L 800 mm X I 500 mm
 Weight: 26 kg
 Power:
 Approval: CE

The glass selector selects and extracts, from the input conveyor, the glasses which fell on the input accumulation table during their transfer. It stores them in a recycling bin. This avoids jams requiring an operator intervent.



▪ UVC STERILISATION



TECHNICAL DATA

Dimensions : H 300 mm X L 1050 mm X I 160 mm
 Weight: 15 kg
 Power: Electrical 230 V AC – 60W
 Approval: CE

The UVC sterilization device allows the decontamination of containers. It uses germicidal lamps protected by an anti-splinter coating and that have a 8000h shelf-life.

▪ TRAY FLIP DEVICE



TECHNICAL DATA

Dimensions : H 1680 mm X L 1780 mm X I 1390 mm
 Weight: 150 kg
 Power: manual
 Approval: CE

All our “OGW patented” cups are packed upside down to insure no insect or dust get in the glasses. The **Tray flip device** helps you flip a full layer of cups (272 units for SIMS19, 36l for DROP19 and WRAP19) in the same time.

▪ CAPPER DEVICE



TECHNICAL DATA

Dimensions: H 650 mm X L 690 mm X I 480 mm
 Weight: 34 kg
 Approval: CE

The semi-automatic **Capper device** is specially designed to be installed on the H8 machine.

During the transport on the conveyor, each glass picks a plastic cap and a roll clips the cap on the glass rim.

The capper uses Plastic caps D53TL. The loading of caps is manual.

■ CAP FEEDER

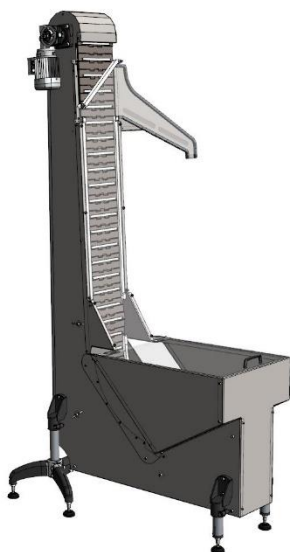

TECHNICAL DATA

Dimensions: H 2 470 mm X L 1300 mm X I 015 mm

Weight: 100 kg

Power: Electrical 230 V AC – 16A

Approval: CE

With a storage capacity of 4,000 plastic caps, the **Cap Feeder** avoid the permanent presence of an operator to load the **Capper device**.

■ OUTPUT TABLE



TECHNICAL DATA

Dimensions: H 1000 mm X L 1030 mm X I 1030 mm

Weight: 75 kg

Power: Electrical 230 V AC – 16A

Approval: CE

With a storage capacity of 250 filled glasses, the **Output table** avoid the permanent presence of an operator at this step of the process



■ SERVICES

➤ Installation

OGW engineers ensure the installation, the commissioning and the training of the production teams.

They are proficient and committed to your success.

They can also provide assistance during the first production runs.

➤ Training

OGW provide specific training according to your needs.

In addition, a very detailed documentation is provided on the operator interface.

➤ Assistance



In case of need of more assistance than the diagnosis and recommendations provided on the operator interface, a hotline is gently available from 8 am to 8 pm CET or on demand.

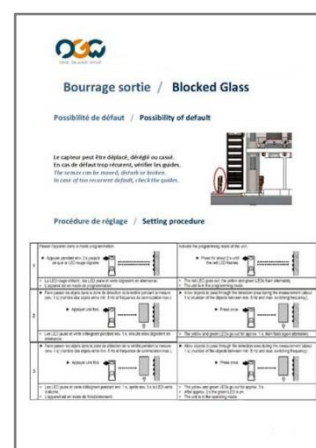

➤ Preventive maintenance

OGW can also offer preventive maintenance contracts to insure the best performance of the filling line.

▪ MACHINES & DEVICES SPECIFICATIONS

Reference	Height mm	Width mm	Depth mm	Weight kg	Electric power	Air pressure bar / psi	Production throughput units / h
H8 Filling machine	2 150	6 555	8 659	756	230 V AC – 32A	8 / 116	Up to 3 600
H4 Filling machine	2 150	6 555	8 659	588	230 V AC – 32A	8 / 116	Up to 1 800
H4-P8 Filling machine	2 150	6 555	8 659	606	230 V AC – 32A	8 / 116	
KP8 Upgrade Kit for H4-P8				150			
Tray flip device	1 680	1 780	1 390	150			
Input accumulation table	1 390	4 190	1 655	310	230 V AC – 16A	8 / 116	
Glass Selector	435	800	500	26	230 V AC – 16A	8 / 116	
P&P device	1 910	1 690	1 480	330	230 V AC – 16A	8 / 116	
Capper	650	690	480	34	230 V AC – 16A		
Cap Feeder	2 047	1 300	1 015	100	230 V AC – 16A		
Sterilisation UVC	300	1 050	160	15	230 V AC – 60W		
Unloader device	850	2 770	1 200	40	230 V AC – 16A	8 / 116	
Output table	1 000	1 030	1 030	75	230 V AC – 16A		

No part of this publication may be reproduced, stored in a retrieval system, or transmitted, in any form or by any means, without the previous written approval of OGW-1/4Vin.

All intellectual property rights, including copyright, are reserved by OGW-1/4Vin.

GENERAL TERMS OF SALES

All our sales are performed under the following terms and conditions accepted by our clients notwithstanding any clause to the contrary, of their own purchasing terms. They shall only depart from the said terms and conditions with our written agreement given in advance for each particular case.

I. ORDER REGISTRATION

All orders shall be sent to I/4VIN - OGW, or confirmed in written to the latter. An order cannot be cancelled by the client without prior acceptance.

II. DELIVERY DATES

Delivery dates are given for information only and shall not imply any official commitment on our part and we shall, in no case, whatsoever, be bound to payment of any compensation, should there be any delay.

III. SHIPMENT

All our goods are sent to the consignee's own risks, even when sent carriage paid. The client can only act against the shipping company, should any losses or damages arise, pursuant to the general shipping regulations, the client shall check the contents or damages in the presence of the delivery agent, they shall also take note of the exact damages on the delivery receipt, have the said notes confirmed by the shipping company within 48 hours following the delivery and by registered letter with acknowledgement of receipt. Delivery can only take place if the client is up to date of his obligations, of any kind, with the company I/4VIN - OGW. In the event of force majeure, war, epidemic, fire, strike, unemployment or any impediment beyond our control, we have the right to suspend the performance of the contract.

IV. PRICE

All our prices are exclusive of VAT and our sales are at thousand pieces or individual pieces, according to the item; said prices are in Euros and may be revised according to the economic conditions prevailing on the date of delivery.

The fixed price for packaging and shipping is applied upon each shipment, according to the weight, unless otherwise specified in the offer. Any express shipment will be chargeable to the consignee whatever the amount of the order. Should an order not be delivered at once further to a rated order, at the request of the client, the transport costs shall apply to each one of the shipments according to its weight.

V. PAYMENT

All our goods are payable at home. We reserve the right, systematically upon the first order or, in the event of an insufficient credit rating of the client or, in the event of repeated payment problems (delays leading to reminders) to claim a cash payment without any entitlement to a discount. Pursuant to the European Directive n. 200/35/CE and to the subsequent French laws, namely law LME n. 2008/776 of 4th August 2008, as from January 2009 our additional term of payment is of 30 days after invoice date. As an exception, some clients may be granted the maximum time-limit authorized by law LME, namely 60 days, end of the month. The date of issue of the invoice shall be the starting point of payment, as provided for herein under. Section L442-6 of the Commercial Code specifies that any time-limit over the legal maximum is illegal and punishable, as well as the fact that a supplier is required to delay the date of invoice. Should any payment be delayed, penalties shall, by right be applied for late payment and as from the day following settlement date specified on the invoice. Said penalties are due without being challenged. They are in an amount equal to one and half times the legal interest rate. In addition to the penalties for late payment, any delay in payment shall give rise to the payment of a lump sum covering the collection costs to the benefit of the vendor. The aforesaid lump sum amounts to €40 (Decree 2012-1115 of 2nd October 2012).

Failing payment of one single term, the full amount of the outstanding payments shall, by right be immediately payable together with the current interests accruing per delayed month of payment.

No claim, should it even be justified, shall authorize the client to defer payment of an invoice. Any claim recovered by our legal department shall be increased, in addition to the default interests, as a fixed-sum compensation for the recovery costs and the various other heads of claim, by compensation set at 20% of the claim to be recovered, adding up the legal fees and expenses.

VI. PROPERTY OF GOODS

By express agreement, we reserve the ownership of the goods supplied until their full payment, pursuant to law 80-335 of 12th May 1980.

VII. CLAIMS

In order to be valid, any claim shall be submitted to I/4VIN - OGW within 15 days following delivery of goods. We shall, in no way accept any returned goods without prior written approval by I/4VIN - OGW.

Should there be any defects in above mentioned goods, our liability is limited to the replacement of defective parts. Any damages shall be excluded.

Defective products shall be returned to us for assessment purposes by an expert. Any returns shall be made within 15 days following delivery; after said limit and without prior approval of our services, a 30% markdown shall be automatically deducted from the credit or from the replacing goods. Should the return not be justified by a dispute that lies with us, the goods shall not be taken back.

The goods shall be returned in their original packages; the mechanical parts shall not have been mounted, marked or soiled, as for the glasses and the caps, the intact packages only shall be taken into account.

Otherwise, the goods shall not be taken back. Any return shall contain your company letterhead voucher with the number of the delivery note, reference of the goods, quantity returned and the reason of the return.

The goods returned shall be sent carriage-paid. Where the case is a shipment error falling to us, then the shipment costs shall be chargeable to us and refunded in credit or parts. We reserve the right to refuse collect shipments.

It is not always possible to record credits before the 30th day of the current month, which is the date of our entries into the accounting books. This shall, in no case justify the retain of a monthly payment.

VIII. ORDERS

Any order placed by the client implies full acceptance of the proposals made by the company I/4VIN - OGW.

As for the orders relating to containers and caps or orders relating to services relating to contract packaging, placing an order implies validation, by the client, of the design of the cap and of the sealing film used and/or of the design of the container and the material used. The company I/4VIN - OGW disclaims any liability regarding compatibility between: cap - container - content - process. It is the responsibility of the client to approve, prior to the order, that our products are the right match to his applications; we are therefore at your disposal to provide you assistance in your tests, supplying you caps and containers, samples, technical assistance, where required.

Studies, plans, documents and prototypes, being the property of the company I/4VIN - OGW, given to you or sent to you, shall, in no way be communicated to thirds; they shall not be executed by any person, whatsoever without prior written special authorization of the company I/4VIN - OGW who is the sole holder of the industrial property rights therein. Client shall protect the company I/4VIN - OGW against the consequences of actions which may be undertaken after performance by I/4VIN - OGW of an order covered by an industrial property right.

The company I/4VIN - OGW shall be bound by its offers only within 3 months, unless otherwise specified. All information provided in our offers (prices, technical and general information) is provided for information purposes; it cannot be used for legal purposes.

IX. GUARANTEE

I/4VIN - OGW products are guaranteed by the manufacturer (I/4VIN - OGW) against any material and manufacturing defects for a 12 months period with a maximum of 1,000,000 products packaged as from the day they are operational. The date is indicated in the 'License Agreement' given to the client.

The guarantee shall not apply in the event of defective wear-and-tear parts and spares listed in the 'Maintenance and Servicing' manual.

• I/4VIN - OGW contractual guarantee covers:

- Repair or free replacement (parts and workmanship) of the parts recognized as defective by the manufacturer or its representative, being well specified herein that said repair or free replacement may be carried out with new parts, new components or standard exchange after assessment of manufacturer or its representative
- Transport and accommodation fees at the breakdown site, service point of the nearest I/4VIN - OGW commercial network
- The guarantee applies under the express condition that:
 - The equipment has always been repaired by the technicians of the I/4VIN - OGW commercial network
 - The maintenance and cleaning operations mentioned in the maintenance manual have regularly been carried out
- The guarantee ceases when:
 - Parts or accessories unapproved by the manufacturer have been mounted on the equipment.
 - Changes or adaptations have been performed whilst they are not planned nor authorized by the manufacturer or carried out without observing the technical specifications specified by said manufacturer.
 - The failure is due to negligence of the user or to the fact that the specifications contained in the user's and maintenance guide have not been observed
 - The equipment is not properly used
 - The equipment is under an overload, even if temporary

- Furthermore, the guarantee shall not cover:
 - The routine maintenance, adjustments and periodic servicing as well as the consumable items such as sealing plates and flatness test, suction cups and heating cartridges.
 - Unless damages have been caused by a mechanical default, being itself covered by the guarantee, the replacement of parts subjected to normal everyday wear due to the current operational use of the said equipment.
 - Damages which occur due to an external cause that damages the equipment, namely chemical fallout, fire on the components or assemblies.
 - Damages due to natural hazards, floods, atmospheric discharges, etc.

The interventions conducted within the Contractual Guarantee do not lead to the extension thereof, unless otherwise provided for.

Parts or assemblies changed under the Contractual Guarantee become the property of the company I/4VIN - OGW.

The company I/4VIN - OGW shall not be held liable for any deterioration of the packaged products, which could occur when using its equipment.

Should the guarantee be applied, neither compensation nor damages shall be claimed.

X. RESERVATION OF PROPERTY

Transfer of our products shall be suspended until full payment of price is made by the client; this includes the principal material and possible accessories and it is also valid if a delayed payment has been granted. Any contrary clause inserted into the terms and conditions has no validity, pursuant to section L.624-16 of the Commercial Code.

By express agreement, our company shall be entitled to use the rights held under the 'Reservation of Property' clause herein with regard to any of its claims, all of its products, in the client's possession, which will be contractually presumed to be unpaid and our company can take said products back or claim them for all of its unpaid invoices without prejudice to its right to rescind the sales in progress.

Nevertheless, the clause hereinabove shall not prevent the risks related to the goods from being transferred to the purchaser as from their delivery to said purchaser.

XI. COMPETENT COURT

Any dispute with respect to the implementation of these General Terms of Sales and their interpretation, their performance and any sales agreements entered into by our company and, any dispute with respect to payment of the price, shall be brought before the Commercial Court of the company's registered office, whatever the place of the order, delivery, payment and method of payment and even in the event of introduction of third parties or multiple defendants.